



**HKH**

**METAL LIGHT DUTY**

**Technical Datasheet**

**Update: Jan-23**



# HKH Light duty metal anchors

## Hollow deck anchor

### Anchor version



HKH  
(M6-M10)

### Benefits

- Anchor for suspended ceilings and overhead support applications
- Maximum use of base material capacity
- Setting without drilling

### Base material



Prestressed hollow core slabs

### Load condition



Fire resistance

### Other information



Corrosion resistance



Sprinkler approved

### Approvals / certificates

Description	Authority / Laboratory	No. / date of issue
Allgemeine bauaufsichtliche Zulassung (national approval in Germany for a single point fastening) <sup>a)</sup>	DIBt, Berlin	Z-21.1-1722 / 2022-01-20
Fire test report	IBMB, Braunschweig	UB 3606 / 8892 / 2002-07-22
Assessment report (fire)	warringtonfire	WF 327804/A / 2013-07-10
Sprinkler	VdS, Cologne	G 4961028 / 2006-09-05

a) All data given in this section according DIBt Z-21.1-1722, issue 2011-10-31.

## Basic loading data

### All data in this section applies to:

- Correct setting (See setting instruction)
- No edge distance and spacing influence
- Hollow decks where  $w \leq 4,2 \cdot e$
- Hollow decks, classification  $\geq C 45/55$
- Concrete  $f_{cc} \geq 50 \text{ N/mm}^2$

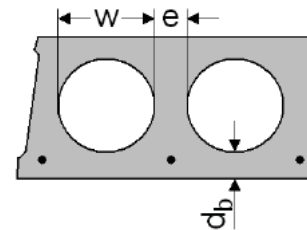

### Recommended loads

Anchor size	M6	M8	M10	M6	M8	M10	M6	M8	M10
Cavity to surface thickness $d_b$ [mm]	$\geq 25$			$\geq 30$			$\geq 40$		
<b>For a single anchor</b>									
Tension <sup>a)</sup> $F_{rec}$ [kN]	0,7	0,7	0,9	0,9	0,9	1,2	2,0	2,0	3,0
<b>For a group of two anchors with a spacing <math>s \geq 100 \text{ mm}</math> and <math>\leq 200 \text{ mm}</math></b>									
Tension <sup>a)</sup> spacing $s \geq 100 \text{ mm}$ $F_{rec}$ [kN]	0,9	0,9	1,2	1,2	1,2	1,6	2,5	2,5	4,0
spacing $s \geq 200 \text{ mm}$ $F_{rec}$ [kN]	1,1	1,1	1,5	1,5	1,5	2,0	3,3	3,3	5,0
<b>For a group of four anchors with a spacing <math>s \geq 100 \text{ mm}</math> and <math>\leq 200 \text{ mm}</math></b>									
Tension <sup>a)</sup> spacing $s \geq 100/100 \text{ mm}$ $F_{rec}$ [kN]	1,2	1,2	1,6	1,6	1,6	2,1	3,5	3,5	5,3
spacing $s \geq 100/200 \text{ mm}$ $F_{rec}$ [kN]	1,5	1,5	2,0	2,0	2,0	2,6	4,4	4,4	6,6
spacing $s \geq 200/200 \text{ mm}$ $F_{rec}$ [kN]	1,9	1,9	2,5	2,5	2,5	3,3	5,5	5,5	8,3

a) The given loads are valid for tension load, shear load and all load directions.

## Materials

### Mechanical properties

Anchor size	M6	M8	M10
Nominal tensile strength $f_{uk}$ Carbon steel [N/mm <sup>2</sup> ]	800	500	500
	700	700	700
Admissible bending resistance [Nm]	7,0	10,7	21,4
	4,9	12,1	24,1

### Material quality

Part	Material
All parts	HKH (Carbon steel)
	HKH (Stainless steel)

Galvanised to min. 5  $\mu\text{m}$   
Stainless steel A4

### Anchor dimension

Anchor size	M6	M8	M10
Thickness of fixture $t_{fix}$ [mm]	$\leq 10$	$\leq 10$	$\leq 10$
Length of the spacer sleeve $l_l$ [mm]	0	0	0
Length of the part of the sleeve $l_{hl}$ [mm]	10	10	10
Anchor diameter $d$ [mm]	9,8	11,8	13,8
Length of the bolt $l$ [mm]	86	88	93
Length of the part of the sleeve $l_h$ [mm]	55		

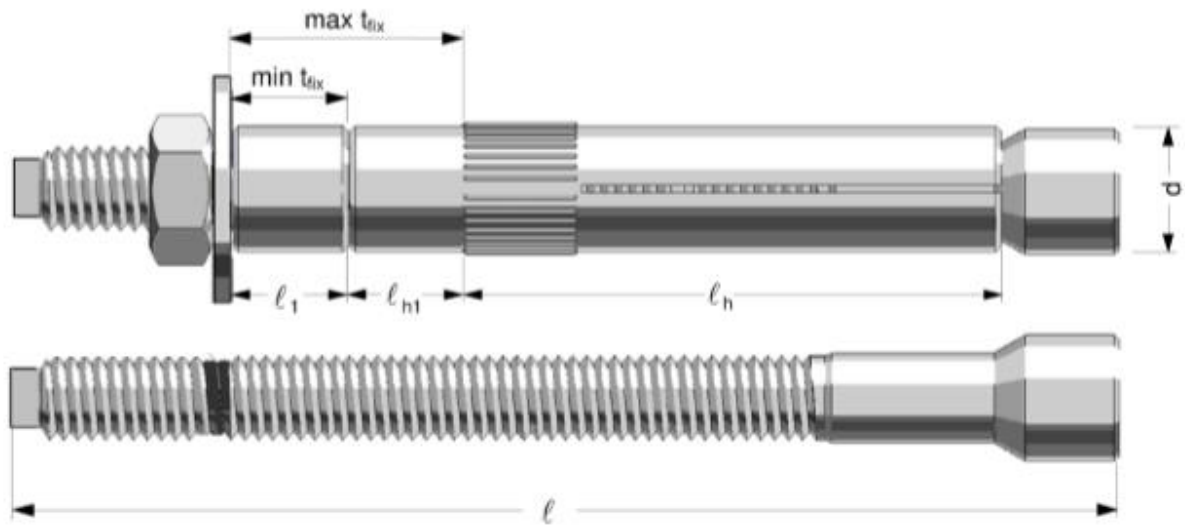

## Setting information

### Setting details

Anchor size		M6	M8	M10
Diameter of clearance hole in the fixture	$d_f \leq$ [mm]	12	14	16
Embedment depth for HKH	$h_s$ [mm]	55 to 65		
Torque moment	$T_{inst}$ [Nm]	5	10	20
Width across	SW [mm]	10	13	17

### Installation equipment

Anchor size	M6	M8	M10
Drill bit	TE-CX-10	TE-CX-12	TE-CX-14
Rotary hammer	TE 6A, TE 6C, TE 6S, TE 15, TE 15-C, TE 18-M		
Setting tools	Torque wrench		
Machine setting tool	available		

### Setting parameters

Anchor size		M6	M8	M10
Edge distance <sup>a)</sup>	$c \geq$ [mm]	150		
	$c_{min} \geq$ [mm]	100		
Spacing between outer anchors of neighbouring fixation	$a \geq$ [mm]	300		

a) For edge distance < 150 mm the recommended load has to be reduced with  $F=0,75 \cdot F_{rec}$ .

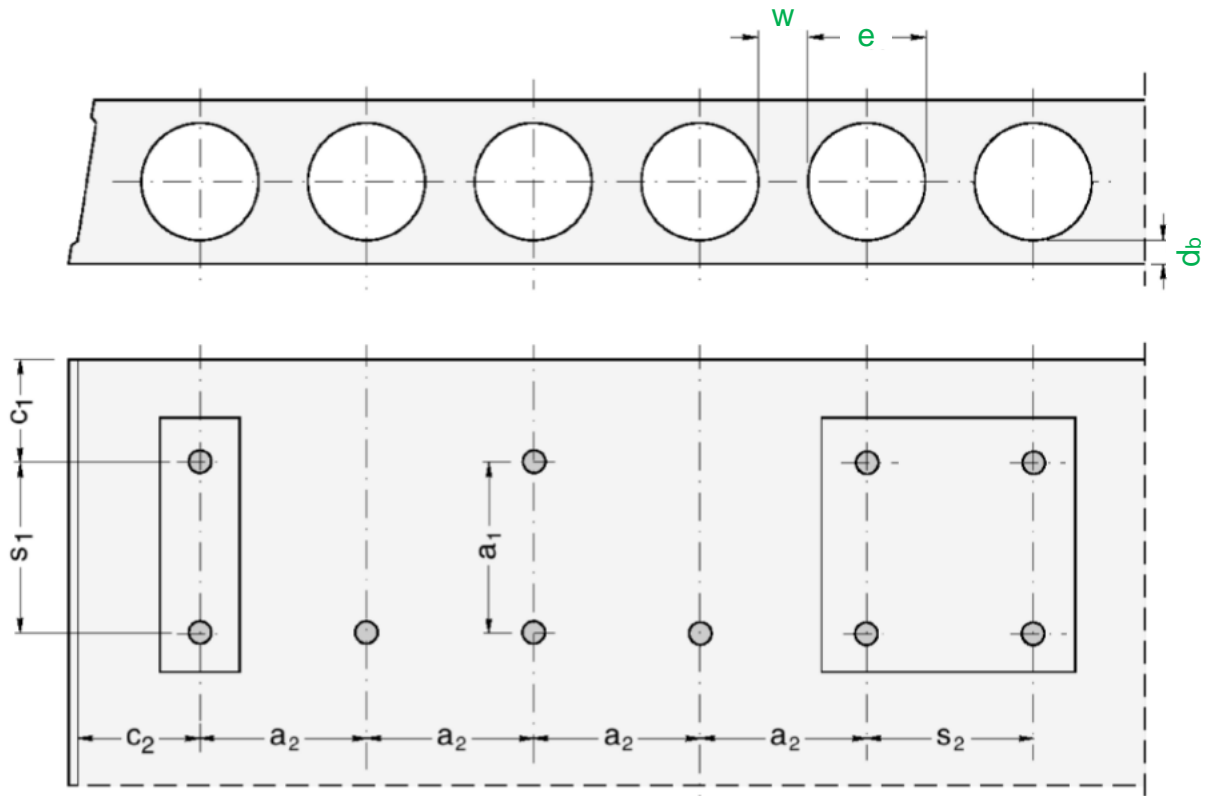

### Setting instruction

\*For detailed information on installation see instruction for use given with the package of the product.

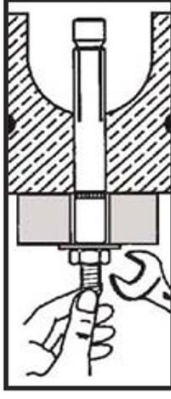
Setting instruction		
<b>1. Drill the hole</b> 	<b>2. Insert the anchor</b> 	<b>3. Setting mark must be visible</b> 