



**HILTI HIT-CT 1**  
**INJECTION MORTAR**  
**ETA-11/0354 (01.09.2020)**





## European Technical Assessment

**ETA-11/0354  
of 01/09/2020**

*English translation prepared by CSTB - Original version in French language*

### General Part

Nom commercial:  
*Trade name*

**Injection system Hilti HIT-CT 1**

Famille de produit :  
*Product family*

Cheville à scellement de type « à injection » pour fixation dans le béton : tailles M8 à M24

**Bonded injection type anchor for use in concrete: sizes M8 to M24**

Titulaire:  
*Manufacturer*

Hilti Corporation  
Feldkircherstrasse 100  
FL-9494 Schaan  
Principality of Liechtenstein

Usine de fabrication:  
*Manufacturing plants*

Hilti plants

Cette évaluation contient:  
*This Assessment contains*

19 pages incluant 16 pages d'annexes qui font partie intégrante de cette évaluation  
*19 pages including 16 annexes which form an integral part of this assessment*

Base de l'ETE:  
*Basis of ETA*

EAD 330499-01-0601  
EAD 330499-01-0601

Cette évaluation remplace:  
*This Assessment replaces*

ETE-11/0354 du 06/09/2019  
*ETA-11/0354 dated 06/09/2019*

## Specific Part

### 1 Technical description of the product

The Hilti HIT-CT 1 injection system is bonded anchor (injection type) consisting of a mortar cartridge with Hilti HIT-CT 1 injection mortar and a steel element.

The steel element can be made of zinc plated carbon steel (HAS-U, HIT-V), reinforcing bar (rebar), stainless steel (HAS-U-A4, HIT-V-R), or high corrosion resistant stainless steel (HAS-U-HCR, HIT-V-HCR).

The steel element is placed into a rotary/percussion drilled hole filled with the injection mortar and is anchored via the bond between the metal part and concrete.

An illustration of the product is provided in Annex A

### 2 Specification of the intended use

The performances given in Section 3 are only valid if the anchor is used in compliance with the specifications and conditions given in Annex B.

The provisions made in this European technical assessment are based on an assumed working life of the anchor of 50 years. The indications given on the working life cannot be interpreted as a guarantee given by the producer, but are to be regarded only as a means for choosing the right products in relation to the expected economically reasonable working life of the works.

### 3 Performance of the product

#### 3.1 Mechanical resistance and stability (BWR 1)

Essential characteristic	Performance
Characteristic resistance for static and quasi static loads, for Hilti HIT-CT 1 with threaded rod, HAS-U, HIT-V	See Annex C1, C2
Characteristic resistance for static and quasi static loads, for Hilti HIT-CT 1 with rebars	See Annex C3, C4
Displacements	See Annex C5

#### 3.2 Safety in case of fire (BWR 2)

Essential characteristic	Performance
Reaction to fire	Anchorage satisfy requirements for Class A1
Resistance to fire	No performance determined (NPD)

#### 3.3 Hygiene, health and the environment (BWR 3)

Regarding dangerous substances contained in this European technical assessment, there may be requirements applicable to the products falling within its scope (e.g. transposed European legislation and national laws, regulations and administrative provisions). In order to meet the provisions of the Construction Products Directive, these requirements need also to be complied with, when and where they apply.

#### 3.4 Safety in use (BWR 4)

For Basic requirement Safety in use the same criteria are valid as for Basic Requirement Mechanical resistance and stability.

#### 3.5 Protection against noise (BWR 5)

Not relevant.

### 3.6 Energy economy and heat retention (BWR 6)

Not relevant.

### 3.7 General aspects relating to fitness for use

Durability and Serviceability are only ensured if the specifications of intended use according to Annex B1 are kept.

## 4 Assessment and verification of constancy of performance (AVCP)

According to the Decision 96/582/EC of the European Commission<sup>1</sup>, as amended, the system of assessment and verification of constancy of performance (see Annex V to Regulation (EU) No 305/2011) given in the following table apply.

Product	Intended use	Level or class	System
Metal anchors for use in concrete	For fixing and/or supporting to concrete, structural elements (which contributes to the stability of the works) or heavy units	—	1

## 5 Technical details necessary for the implementation of the AVCP system

Technical details necessary for the implementation of the Assessment and verification of constancy of performance (AVCP) system are laid down in the control plan deposited at Centre Scientifique et Technique du Bâtiment.

The manufacturer shall, on the basis of a contract, involve a notified body approved in the field of anchors for issuing the certificate of conformity CE based on the control plan.

Issued in Marne La Vallée on 01/09/2020 by

La cheffe de division, Anca CRONOPOL

*The original French version is signed*

---

<sup>1</sup> Official Journal of the European Communities L 254 of 08.10.1996

## Installation conditions

**Figure A1:**

Threaded rod, HAS-U-..., HIT-V-... and AM 8.8

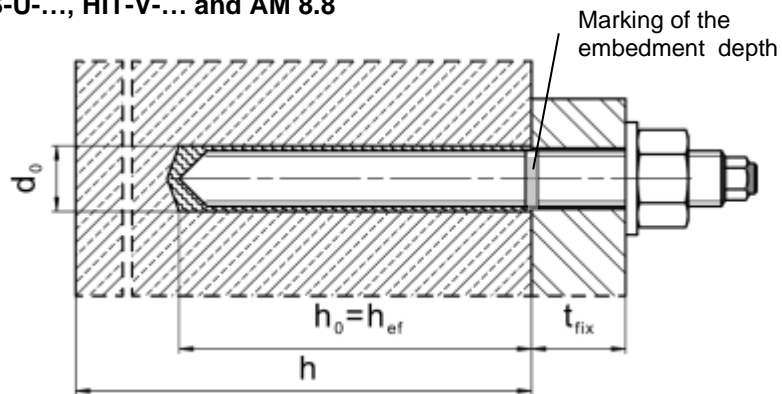

**Figure A2:**

Reinforcing bar (rebar)

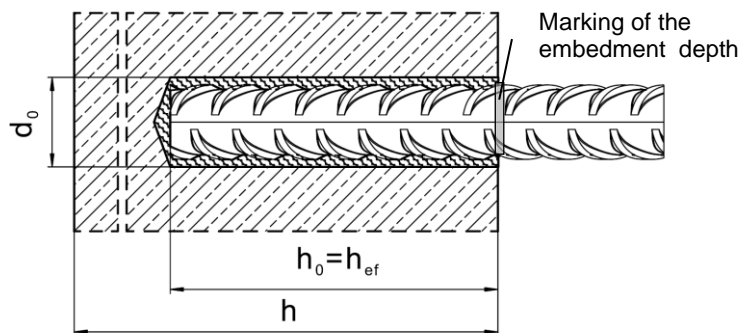

Injection system Hilti HIT-CT 1

Product description  
Installed condition

Annex A1

**Injection mortar Hilti HIT-CT 1:**  
 hybrid system with resin, hardener and cement water component  
**Foil pack 330ml and 500ml**

Marking:  
 Hilti HIT-CT 1  
 Production date  
 Production time and line  
 Expiry date mm/yyyy



Product name: "Hilti HIT-CT 1"

**Static mixer Hilti HIT-RE-M**



**Steel elements**



**HAS-U-...: M8 to M24**

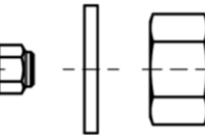

washer

nut

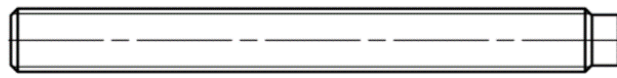

**HIT-V-...: M8 to M24**

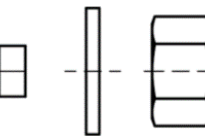

washer

nut

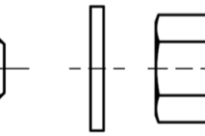
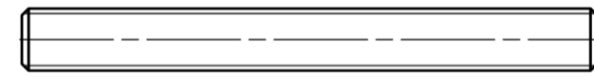

washer

nut

**Threaded rod: M8 to M24**

**Hilti AM 8.8 meter rod electroplated zinc coated: M8 to M24, 1m to 3m**

**Hilti AM HDG 8.8 meter rod hot dip galvanized: M8 to M24, 1m to 3m**

Commercial standard threaded rod with:

- Materials and mechanical properties according to Table A1.
- Inspection certificate 3.1 according to EN 10204:2004. The document shall be stored.
- Marking of embedment depth.



**Reinforcing bar (rebar):  $\phi$  8 to  $\phi$  25**

- Materials and mechanical properties according to Table A1.
- Dimensions according to Annex B3

**Injection system Hilti HIT-CT 1**

**Product description**

Injection mortar / Static mixer / Steel elements

**Annex A2**

**Table A1: Materials**

Designation	Material
<b>Reinforcing bars (rebars)</b>	
Rebar EN 1992-1-1:2004 and AC:2010, Annex C	Bars and de-coiled rods class B or C with $f_{yk}$ and $k$ according to NDP or NCL of EN 1992-1-1/NA:2013 $f_{uk} = f_{tk} = k \cdot f_{yk}$
<b>Metal parts made of zinc coated steel</b>	
HAS-U-5.8(HDG), HIT-V-5.8(HDG), Threaded rod	Strength class 5.8, $f_{uk} = 500 \text{ N/mm}^2$ , $f_{yk} = 400 \text{ N/mm}^2$ Elongation at fracture ( $l_0 = 5d$ ) > 8% ductile Electroplated zinc coated $\geq 5 \mu\text{m}$ , (F) or (HDG) hot dip galvanized $\geq 45 \mu\text{m}$
HAS-U-8.8(F), HIT-V-8.8(F), Threaded rod	Strength class 8.8, $f_{uk} = 800 \text{ N/mm}^2$ , $f_{yk} = 640 \text{ N/mm}^2$ Elongation at fracture ( $l_0 = 5d$ ) > 12% ductile Electroplated zinc coated $\geq 5 \mu\text{m}$ , (F) or (HDG) hot dip galvanized $\geq 45 \mu\text{m}$
Hilti Meter rod AM 8.8 (HDG)	Strength class 8.8, $f_{uk} = 800 \text{ N/mm}^2$ , $f_{yk} = 640 \text{ N/mm}^2$ Elongation at fracture ( $l_0 = 5d$ ) > 12% ductile Electroplated zinc coated $\geq 5 \mu\text{m}$ , or (HDG) hot dip galvanized $\geq 45 \mu\text{m}$
Washer	Electroplated zinc coated $\geq 5 \mu\text{m}$ , hot dip galvanized $\geq 45 \mu\text{m}$
Nut	Strength class of nut adapted to strength class of threaded rod. Electroplated zinc coated $\geq 5 \mu\text{m}$ , hot dip galvanized $\geq 45 \mu\text{m}$
<b>Metal parts made of stainless steel corrosion resistance class III according EN 1993-1-4:2006+A1:2015-06</b>	
HAS-U-A4, HIT-V-R	Strength class 70, $f_{uk} = 700 \text{ N/mm}^2$ , $f_{yk} = 450 \text{ N/mm}^2$ Elongation at fracture ( $l_0 = 5d$ ) > 8% ductile Stainless steel A4 according to EN 10088-1: 2014
Threaded rod	Strength class 70, $f_{uk} = 700 \text{ N/mm}^2$ , $f_{yk} = 450 \text{ N/mm}^2$ Elongation at fracture ( $l_0 = 5d$ ) > 8% ductile Stainless steel 1.4401, 1.4404, 1.4578, 1.4571, 1.4439, 1.4362 EN 10088-1:2014
Washer	Stainless steel A4 according to EN 10088-1: 2014
Nut	Strength class of nut adapted to strength class of threaded rod. Stainless steel A4 according to EN 10088-1: 2014
<b>Metal parts made of stainless steel corrosion resistance class V according EN 1993-1-4:2006+A1:2015-06</b>	
HAS-U-HCR, HIT-V-HCR	For $\leq \text{M20}$ : $f_{uk} = 800 \text{ N/mm}^2$ , $f_{yk} = 640 \text{ N/mm}^2$ For $> \text{M20}$ : $f_{uk} = 700 \text{ N/mm}^2$ , $f_{yk} = 400 \text{ N/mm}^2$ , Elongation at fracture ( $l_0 = 5d$ ) > 8% ductile High corrosion resistant steel according to EN 10088-1:2014
Threaded rod	For $\leq \text{M20}$ : $f_{uk} = 800 \text{ N/mm}^2$ , $f_{yk} = 640 \text{ N/mm}^2$ For $> \text{M20}$ : $f_{uk} = 700 \text{ N/mm}^2$ , $f_{yk} = 400 \text{ N/mm}^2$ , Elongation at fracture ( $l_0 = 5d$ ) > 8% ductile High corrosion resistant steel 1.4529, 1.4565 EN 10088-1:2014
Washer	High corrosion resistant steel according to EN 10088-1:2014
Nut	Strength class of nut adapted to strength class of threaded rod. High corrosion resistant steel according to EN 10088-1:2014

**Injection system Hilti HIT-CT 1**

**Product description**  
Materials

**Annex A3**

## Specifications of intended use

### Anchorage subject to:

- Static and quasi static loading in concrete.

### Base material:

- Reinforced or unreinforced normal weight concrete according to EN 206-1:2013+A1:2016.
- Strength classes C20/25 to C50/60 according to EN 206-1:2013+A1:2016.
- Uncracked and cracked concrete.
- Dry or wet concrete (not in water-filled drill holes)

### Temperature in the base material:

- **At installation**  
-5 °C to +40 °C
- **In-service**  
Temperature range I: -40 °C to +40 °C  
(max. long term temperature +24 °C and max. short term temperature +40 °C)  
Temperature range II: -40 °C to +80 °C  
(max. long term temperature +50 °C and max. short term temperature +80 °C)

### Use conditions (Environmental conditions):

- Structures subject to dry internal conditions  
zinc coated steel (threaded rods, HAS-U, HIT-V), stainless steel (threaded rods, HAS-U-A4, HIT-V-R) or high corrosion resistant steel (threaded rods, HAS-U-HCR, HIT-V-HCR).
- Structures subject to external atmospheric exposure including industrial and marine environment or exposure in permanently damp internal conditions, if no particular aggressive conditions exist.  
stainless steel (threaded rods, HAS-U-A4, HIT-V-R) or high corrosion resistant steel (threaded rods, HAS-U-HCR, HIT-V-HCR).
- Structures subject to permanently damp internal condition or in other particular aggressive conditions  
high corrosion resistant steel (threaded rods, HAS-U-HCR, HIT-V-HCR).

*Note: Particular aggressive conditions are e.g. permanent, alternating immersion in seawater or the splash zone of seawater, chloride atmosphere of indoor swimming pools or atmosphere with extreme chemical pollution (e.g. in desulphurization plants or road tunnels where de-icing materials are used).*

### Design:

- Anchorages are designed under the responsibility of an engineer experienced in anchorages and concrete work.
- Verifiable calculation notes and drawings are prepared taking account of the forces to be transmitted. The position of the anchor is indicated on the design drawings (e. g. position of the anchor relative to reinforcement or to supports, etc.).
- Anchorages under static or quasi-static loading are designed in accordance with EN 1992-4:2018

Injection system Hilti HIT-CT 1

Intended use  
Specifications

Annex B1



**Table B2: Installation parameters of threaded rod, HAS-U and HIT-V**

Threaded rod, HAS-U-..., HIT-V-...	M8	M10	M12	M16	M20	M24
Diameter of element d [mm]	8	10	12	16	20	24
Nominal diameter of drill bit d <sub>0</sub> [mm]	10	12	14	18	22	28
Threaded rod, HAS-U-..., HIT-V-...: Effective embedment depth and drill hole depth h <sub>ef</sub> = h <sub>0</sub> [mm]	64 to 96	80 to 120	96 to 144	128 to 192	160 to 240	192 to 288
Maximum diameter of clearance hole in the fixture d <sub>f</sub> [mm]	9	12	14	18	22	26
Minimum thickness of concrete member h <sub>min</sub> [mm]	h <sub>ef</sub> + 30 ≥ 100 mm			h <sub>ef</sub> + 2·d <sub>0</sub>		
Maximum torque T <sub>max</sub> [Nm]	10	20	40	80	150	200
Minimum spacing s <sub>min</sub> [mm]	40	50	60	80	100	120
Minimum edge distance c <sub>min</sub> [mm]	40	45	45	50	55	60

**HAS-U-...**

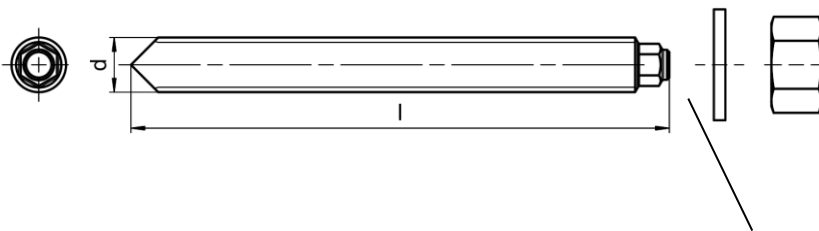

**Marking:**

Steel grade number and length identification letter: e.g. 8L

**HIT-V-...**

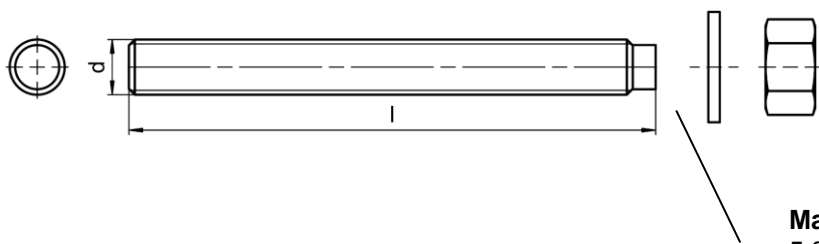

**Marking:**

- 5.8 - l = HIT-V-5.8 M...x l
- 5.8F - l = HIT-V-5.8F M...x l
- 8.8 - l = HIT-V-8.8 M...x l
- 8.8F - l = HIT-V-8.8F M...x l
- R - l = HIT-V-R M ...x l
- HCR - l = HIT-V-HCR M ...x l

Injection system Hilti HIT-CT 1

Intended use  
 Installation parameters

Annex B2

**Table B3: Installation parameters of reinforcing bar (rebar)**

Reinforcing bar (rebar)			$\phi$ 8	$\phi$ 10	$\phi$ 12	$\phi$ 14	$\phi$ 16	$\phi$ 20	$\phi$ 25	
Diameter	$\phi$	[mm]	8	10	12	14	16	20	25	
Effective embedment depth and drill hole depth	$h_{ef} = h_0$	[mm]	64 to 96	80 to 120	96 to 144	112 to 168	128 to 192	160 to 240	200 to 300	
Nominal diameter of drill bit	$d_0$	[mm]	10 <sup>1)</sup> 12 <sup>1)</sup>	12 <sup>1)</sup> 14 <sup>1)</sup>	14 <sup>1)</sup>	16 <sup>1)</sup>	18	20	25	30 <sup>1)</sup> 32 <sup>1)</sup>
Minimum thickness of concrete member	$h_{min}$	[mm]	$h_{ef} + 30$ $\geq 100$ mm			$h_{ef} + 2 \cdot d_0$				
Minimum spacing	$s_{min}$	[mm]	40	50	60	70	80	100	125	
Minimum edge distance	$c_{min}$	[mm]	40	45	45	50	50	65	70	

<sup>1)</sup> Each of the two given values can be used.

**Reinforcing bar (rebar)**



For rebar bolt

- Minimum value of related rib area  $f_{R,min}$  according to EN 1992-1-1:2004+AC:2010.
- Rib height of the bar  $h_{rib}$  shall be in the range  $0,05 \cdot \phi \leq h_{rib} \leq 0,07 \cdot \phi$   
 ( $\phi$ : Nominal diameter of the bar;  $h_{rib}$ : Rib height of the bar).

**Injection system Hilti HIT-CT 1**

**Intended use**  
 Installation parameters

**Annex B3**

**Table B4: Minimum curing time<sup>1)</sup>**

Temperature in the base material T	Maximum working time $t_{work}$	Minimum curing time $t_{cure}^{1)}$
-5 °C to -1 °C	60 min	6 hours
0 °C to 4 °C	40 min	3 hours
5 °C to 9 °C	25 min	2 hours
10 °C to 19 °C	10 min	90 min
20 °C to 29 °C	4 min	75 min
30 °C to 40 °C	2 min	60 min

<sup>1)</sup> The curing time data are valid for dry base material only. In wet base material the curing times must be doubled.







**Injection system Hilti HIT-CT 1**

**Intended use**

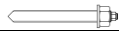

Maximum working time and minimum curing time

**Annex B4**

**Table B5: Parameters of cleaning and setting tools**

Elements		Drill and clean			Installation
Threaded rod, HAS-U-..., HIT-V-...	Rebar	Hammer drilling		Brush	Piston plug
		Drill bit	Hollow drill bit TE-CD, TE-YD		
					
Size	Size	d <sub>0</sub> [mm]	d <sub>0</sub> [mm]	HIT-RB	HIT-SZ
M8	φ 8	10	-	10	-
M10	φ 8, φ 10	12	-	12	12
M12	φ 10, φ 12	14	14	14	14
-	φ 12	16	16	16	16
M16	φ 14	18	18	18	18
-	φ 16	20	20	20	20
M20	-	22	22	22	22
-	φ 20	25	25	25	25
M24	-	28	28	28	28
-	φ 25	30	30	30	30
-	φ 25	32	32	32	32

**Cleaning alternatives**

<p><b>Manual Cleaning (MC):</b>                  Hilti hand pump for blowing out drill holes with diameters d<sub>0</sub> ≤ 20 mm and drill hole depth h<sub>0</sub> ≤ 10d</p>	
<p><b>Compressed Air Cleaning (CAC):</b>                  air nozzle with an orifice opening of minimum 3,5 mm in diameter.</p>	
<p><b>Automatic Cleaning (AC):</b>                  Cleaning is performed during drilling with Hilti TE-CD and TE-YD drilling system including vacuum cleaner.</p>	

**Injection system Hilti HIT-CT 1**

**Intended use**

Parameters of cleaning and setting tools  
 Cleaning alternatives

**Annex B5**

## Installation instruction

### Hole drilling

**a) Hammer drilling:** For dry or wet concrete only.

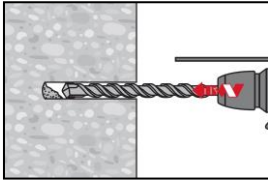

Drill hole to the required embedment depth with a hammer drill set in rotation-hammer mode using an appropriately sized carbide drill bit.

**b) Hammer drilling with Hilti hollow drill bit TE-CD, TE-YD:** For dry and wet concrete only.

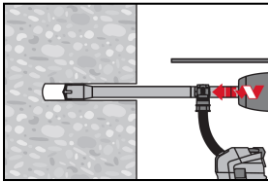

Drill hole to the required embedment depth with an appropriately sized Hilti TE-CD or TE-YD hollow drill bit with Hilti vacuum attachment. This drilling system removes the dust and cleans the drill hole during drilling when used in accordance with the user's manual. After drilling is completed, proceed to the "injection preparation" step in the installation instruction.

Injection system Hilti HIT-CT 1

Intended use  
Installation instructions

Annex B6

**Drill hole cleaning:** Just before setting an anchor, the drill hole must be free of dust and debris.  
 Inadequate hole cleaning = poor load values.

**Manual Cleaning (MC):** Uncracked concrete. For drill hole diameters  $d_0 \leq 20$  mm and drill hole depths  $h_0 \leq 10 \cdot d$

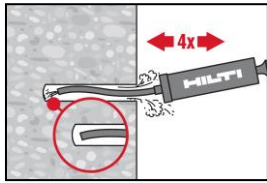

The Hilti hand pump may be used for blowing out drill holes up to diameters  $d_0 \leq 20$  mm and embedment depths up to  $h_{ef} \leq 10 \cdot d$ .  
 Blow out at least 4 times from the back of the drill hole until return air stream is free of noticeable dust.

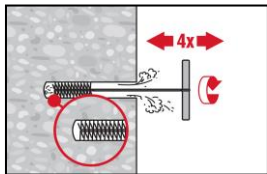

Brush 4 times with the specified brush (see Table B5) by inserting the steel brush Hilti HIT-RB to the back of the hole (if needed with extension) in a twisting motion and removing it.  
 The brush must produce natural resistance as it enters the drill hole (brush  $\varnothing \geq$  drill hole  $\varnothing$ ) - if not the brush is too small and must be replaced with the proper brush diameter.

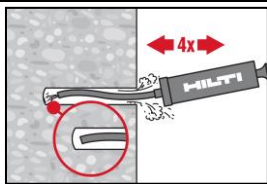

Blow out again with the Hilti hand pump at least 4 times until return air stream is free of noticeable dust.

**Compressed Air Cleaning (CAC):** For all drill hole diameters  $d_0$  and all drill hole depths  $h_0$ .

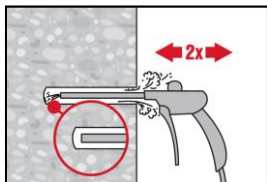

Blow 2 times from the back of the hole (if needed with nozzle extension) over the whole length with oil-free compressed air (min. 6 bar at 6 m<sup>3</sup>/h) until return air stream is free of noticeable dust.  
 For drill hole diameters  $\geq 32$  mm the compressor has to supply a minimum air flow of 140 m<sup>3</sup>/h.

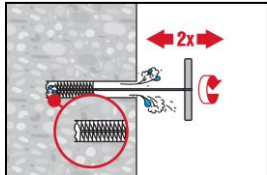

Brush 2 times with the specified brush (see Table B5) by inserting the steel brush Hilti HIT-RB to the back of the hole (if needed with extension) in a twisting motion and removing it.  
 The brush must produce natural resistance as it enters the drill hole (brush  $\varnothing \geq$  drill hole  $\varnothing$ ) - if not the brush is too small and must be replaced with the proper brush diameter.

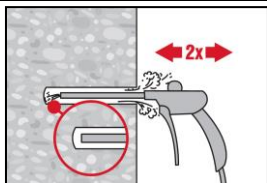

Blow again with compressed air 2 times until return air stream is free of noticeable dust.

Injection system Hilti HIT-CT 1

Intended use  
 Installation instructions

Annex B7

### Injection preparation

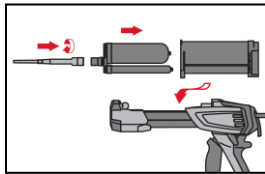

Tightly attach Hilti mixing nozzle HIT-RE-M to foil pack manifold. Do not modify the mixing nozzle.  
 Observe the instruction for use of the dispenser.  
 Check foil pack holder for proper function. Insert foil pack into foil pack holder and put holder into dispenser.

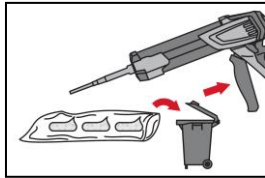

Discard initial adhesive. The foil pack opens automatically as dispensing is initiated. Depending on the size of the foil pack an initial amount of adhesive has to be discarded.  
 Discard quantities are 2 strokes for 330ml foil pack and 3 strokes for 500ml foil pack

### Inject adhesive from the back of the drill hole without forming air voids.

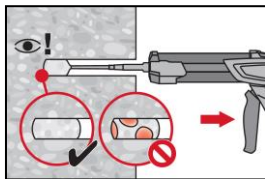

Inject the adhesive starting at the back of the hole, slowly withdrawing the mixer with each trigger pull.  
 Fill approximately 2/3 of the drill hole to ensure that the annular gap between the anchor and the concrete is completely filled with adhesive along the embedment length.

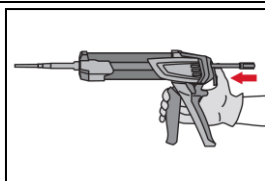

After injection is completed, depressurize the dispenser by pressing the release trigger. This will prevent further adhesive discharge from the mixer.

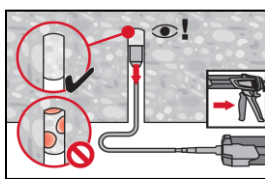

Overhead installation and/or installation with embedment depth  $h_{ef} > 250$  mm. For overhead installation the injection is only possible with the aid of extensions and piston plugs. Assemble HIT-RE-M mixer, extension(s) and appropriately sized piston plug (see Table B5). Insert piston plug to back of the hole and inject adhesive. During injection the piston plug will be naturally extruded out of the drill hole by the adhesive pressure.

### Setting the element

Just before setting an anchor, the drill hole must be free of dust and debris.

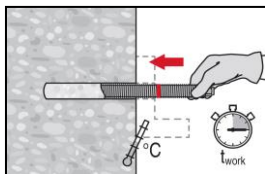

Before use, verify that the element is dry and free of oil and other contaminants. Mark and set element to the required embedment depth before working time  $t_{work}$  has elapsed. The working time  $t_{work}$  is given in Table B4.

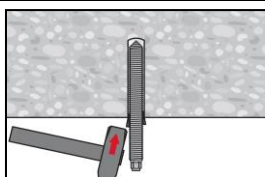

For overhead installation use piston plugs and fix embedded parts with e.g. wedges.

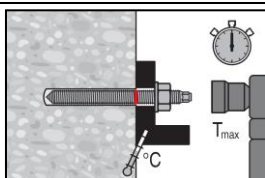

Loading the anchor: After required curing time  $t_{cure}$  (see Table B4) the anchor can be loaded. The applied installation torque shall not exceed the values  $T_{max}$  given in Table B2.

Injection system Hilti HIT-CT 1

Intended use  
 Installation instructions

Annex B8

**Table C1: Essential characteristics for threaded rods under tension load in concrete**

Threaded rod, HAS-U-..., HIT-V-...			M8	M10	M12	M16	M20	M24
<b>Installation safety factor</b>								
Hammer drilling	$\gamma_{inst}$	[-]	1,2					
Hammer drilling with Hilti hollow drill bit TE-CD or TE-YD	$\gamma_{inst}$	[-]	-	1,2				
<b>Steel failure threaded rods</b>								
Characteristic resistance	$N_{Rk,s}$	[kN]	$A_s \cdot f_{uk}$					
Partial factor Grade 5.8	$\gamma_{Ms,N}^{1)}$	[-]	1,5					
Partial factor Grade 8.8	$\gamma_{Ms,N}^{1)}$	[-]	1,5					
Partial factor HAS-U-A4, HIT-V-R	$\gamma_{Ms,N}^{1)}$	[-]	1,87					
Partial factor HAS-U-HCR, HIT-V-HCR	$\gamma_{Ms,N}^{1)}$	[-]	1,5					2,1
<b>Combined pullout and concrete cone failure</b>								
Uncracked concrete C20/25								
Temperature range I: 40°C / 24°C	$\tau_{Rk,ucr}$	[N/mm <sup>2</sup> ]	12	11	11	10	9,5	9,0
Temperature range II: 80°C / 50°C	$\tau_{Rk,ucr}$	[N/mm <sup>2</sup> ]	11	11	10	9,5	9,0	8,5
Cracked concrete C20/25								
Temperature range I: 40°C / 24°C	$\tau_{Rk,cr}$	[N/mm <sup>2</sup> ]	-	2,5	2,5	2,5	-	-
Temperature range II: 80°C / 50°C	$\tau_{Rk,cr}$	[N/mm <sup>2</sup> ]	-	2,5	2,5	2,5	-	-
<b>Influence factors <math>\psi</math> on bond resistance <math>\tau_{Rk}</math></b>								
Influence of concrete strength								
Uncracked concrete: Factor for concrete compressive strength	$\psi_c$	C30/37	1,06					
		C40/50	1,11					
		C50/60	1,15					
Cracked concrete: Factor for concrete compressive strength	$\psi_c$	C30/37	1,00					
		C40/50	1,00					
		C50/60	1,00					
<b>Concrete cone failure</b>								
Factor for uncracked concrete	$k_{ucr}$	[-]	11,0					
Factor for cracked concrete	$k_{cr}$	[-]	7,7					
Edge distance	$c_{cr,N}$	[mm]	$1,5 \cdot h_{ef}$					
Spacing	$s_{cr,N}$	[mm]	$3,0 \cdot h_{ef}$					

<sup>1)</sup> In absence of national regulations.

**Injection system Hilti HIT-CT 1**

**Performances**

Essential characteristics under tension load in concrete

**Annex C1**



Table C2: continued

Threaded rod, HAS-U-..., HIT-V-...			M8	M10	M12	M16	M20	M24
<b>Splitting failure</b>								
Edge distance $c_{cr,sp}$ [mm] for	$h / h_{ef} \geq 2,0$		$1,0 \cdot h_{ef}$					
	$2,0 > h / h_{ef} > 1,3$		$4,6 \cdot h_{ef} - 1,8 \cdot h$					
	$h / h_{ef} \leq 1,3$		$2,26 \cdot h_{ef}$					
Spacing	$s_{cr,sp}$	[mm]	$2 \cdot c_{cr,sp}$					

Injection system Hilti HIT-CT 1

**Performances**

Essential characteristics under tension load in concrete

Annex C1

**Table C3: Essential characteristics for threaded rods under shear load concrete**

Threaded rod, HAS-U-..., HIT-V-...			M8	M10	M12	M16	M20	M24
<b>Steel failure without lever arm</b>								
Characteristic resistance	$V_{Rk,s}$	[kN]	$0,5 \cdot A_s \cdot f_{uk}$					
Partial factor grade 5.8	$\gamma_{Ms,v}^{1)}$	[-]	1,25					
Partial factor grade 8.8	$\gamma_{Ms,v}^{1)}$	[-]	1,25					
Partial factor HAS-U-A4, HIT-V-R	$\gamma_{Ms,v}^{1)}$	[-]	1,56					
Partial factor HAS-U-HCR, HIT-V-HCR	$\gamma_{Ms,v}^{1)}$	[-]	1,25					1,75
Ductility factor	$k_7$	[-]	1,0					
<b>Steel failure with lever arm</b>								
Bending moment	$M_{Rk,s}^0$	[Nm]	$1,2 \cdot W_{el} \cdot f_{uk}$					
Ductility factor	$k_7$	[-]	1,0					
<b>Concrete pry-out failure</b>								
Pry-out factor	$k_8$	[-]	2,0					
<b>Concrete edge failure</b>								
Effective length of fastener	$l_f$	[mm]	$\min (h_{ef} ; 12 \cdot d_{nom})$					
Outside diameter of the anchor	$d_{nom}$	[mm]	8	10	12	16	20	24

<sup>1)</sup> In absence of national regulations.

**Injection system Hilti HIT-CT 1**

**Performances**

Essential characteristics under shear load in uncracked concrete

**Annex C2**

**Table C4: Essential characteristics for reinforcing bars (rebars) under tension load in uncracked concrete**

Reinforcing bar (rebar)		$\phi$ 8	$\phi$ 10	$\phi$ 12	$\phi$ 14	$\phi$ 16	$\phi$ 20	$\phi$ 25	
<b>Installation safety factor</b>									
Hammer drilling	$\gamma_{inst}$	[-]		1,2					
Hammer drilling with Hilti hollow drill bit TE-CD or TE-YD	$\gamma_{inst}$	[-]		-	1,2				
<b>Steel failure</b>									
Rebar B500B acc. to DIN 488:2009-08 <sup>2)</sup>	$N_{Rk,s}$	[kN]	28	43	62	85	111	173	270
Partial factor <sup>3)</sup>	$\gamma_{Ms,N}$ <sup>1)</sup>	[-]		1,4					
<b>Combined pullout and concrete cone failure</b>									
Uncracked concrete C20/25									
Temperature range I: 40°C / 24°C	$\tau_{Rk,ucr}$	[N/mm <sup>2</sup> ]	7,0	7,5	7,5	7,5	7,5	8,0	8,0
Temperature range II: 80°C / 50°C	$\tau_{Rk,ucr}$	[N/mm <sup>2</sup> ]	7,0	7,0	7,0	7,0	7,0	7,5	7,5
<b>Influence factors <math>\psi</math> on bond resistance <math>\tau_{Rk}</math></b>									
Influence of concrete strength									
Factor for concrete compressive strength	$\psi_c$	C30/37	1,06						
		C40/50	1,11						
		C50/60	1,15						
<b>Concrete cone failure</b>									
Factor for uncracked concrete	$k_{Ucr}$	[-]		11,0					
Factor for cracked concrete	$k_{Cr}$	[-]		7,7					
Edge distance	$c_{Cr,N}$	[mm]		1,5 · $h_{ef}$					
Spacing	$s_{Cr,N}$	[mm]		3,0 · $h_{ef}$					
<b>Splitting failure</b>									
Edge distance $c_{Cr,sp}$ [mm] for		$h / h_{ef} \geq 2,0$	$1,0 \cdot h_{ef}$						
		$2,0 > h / h_{ef} > 1,3$	$4,6 \cdot h_{ef} - 1,8 \cdot h$						
		$h / h_{ef} \leq 1,3$	$2,26 \cdot h_{ef}$						
Spacing	$s_{Cr,sp}$	[mm]		$2 \cdot c_{Cr,sp}$					

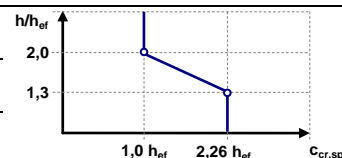

- 1) In absence of national regulations.
- 2) Values need to be calculated acc. EAD 330499-01, Eq. 2.1, if rebars do not fulfil the requirements acc. DIN 488.
- 3) Values need to be calculated acc. EN 1992-4:2018, tab 4.1, if rebars do not fulfil the requirements acc. DIN 488.

**Injection system Hilti HIT-CT 1**

**Performances**

Essential characteristics under tension load in uncracked concrete

**Annex C3**

**Table C5: Essential characteristics for reinforcing bars (rebars) under shear load in uncracked concrete**

Reinforcing bar (rebar)	$\phi$ 8	$\phi$ 10	$\phi$ 12	$\phi$ 14	$\phi$ 16	$\phi$ 20	$\phi$ 25
<b>Steel failure without lever arm</b>							
Rebar B500B acc. to DIN 488:2009-08 <sup>2)</sup> $V_{Rk,s}$ [kN]	14	22	31	42	55	86	135
Partial factor <sup>3)</sup> $\gamma_{Ms,V}$ <sup>1)</sup> [-]	1,5						
Ductility factor $k_7$ [-]	1,0						
<b>Steel failure with lever arm</b>							
Rebar B500B acc. to DIN 488:2009-08 <sup>2)</sup> $M^0_{Rk,s}$ [Nm]	33	65	112	178	265	518	1012
Partial factor <sup>3)</sup> $\gamma_{Ms,V}$ <sup>1)</sup> [-]	1,5						
Ductility factor $k_7$ [-]	1,0						
<b>Concrete pryout failure</b>							
Pry-out factor $k_8$ [-]	2,0						
<b>Concrete edge failure</b>							
Effective length of fastener $l_f$ [mm]	min ( $h_{ef}$ ; $12 \cdot d_{nom}$ )						min ( $h_{ef}$ ; 300)
Outside diameter of the anchor $d_{nom}$ [mm]	8	10	12	14	16	20	25

1) In absence of national regulations.

2) Values need to be calculated acc. EAD 330499-01, Eq. 2.1, if rebars do not fulfil the requirements acc. DIN 488.

3) Values need to be calculated acc. EN 1992-4:2018, tab 4.1, if rebars do not fulfil the requirements acc. DIN 488.

**Injection system Hilti HIT-CT 1**

**Performances**

Essential characteristics under shear load in uncracked concrete

**Annex C4**

**Table C6: Displacements under tension load**

Threaded rod, HAS-U-..., HIT-V-...			M8	M10	M12	M16	M20	M24
<b>Uncracked concrete</b>								
Temperature range I: 40°C / 24°C								
Displacement	$\delta_{N0}$	[mm/(N/mm <sup>2</sup> )]	0,06	0,06	0,06	0,07	0,07	0,07
Displacement	$\delta_{N\infty}$	[mm/(N/mm <sup>2</sup> )]	0,07	0,07	0,07	0,08	0,08	0,08
Temperature range II: 80°C / 50°C								
Displacement	$\delta_{N0}$	[mm/(N/mm <sup>2</sup> )]	0,06	0,06	0,06	0,07	0,07	0,07
Displacement	$\delta_{N\infty}$	[mm/(N/mm <sup>2</sup> )]	0,07	0,07	0,07	0,08	0,08	0,08
<b>Cracked concrete</b>								
Temperature range I: 40°C / 24°C								
Displacement	$\delta_{N0}$	[mm/(N/mm <sup>2</sup> )]	-	0,22	0,34	0,37	-	-
Displacement	$\delta_{N\infty}$	[mm/(N/mm <sup>2</sup> )]	-	0,22	0,34	0,37	-	-
Temperature range II: 80°C / 50°C								
Displacement	$\delta_{N0}$	[mm/(N/mm <sup>2</sup> )]	-	0,22	0,34	0,37	-	-
Displacement	$\delta_{N\infty}$	[mm/(N/mm <sup>2</sup> )]	-	0,22	0,34	0,37	-	-

**Table C7: Displacements under shear load**

Threaded rod, HAS-U-..., HIT-V-...,			M8	M10	M12	M16	M20	M24
Displacement	$\delta_{V0}$	[mm/kN]	0,06	0,06	0,05	0,04	0,04	0,03
Displacement	$\delta_{V\infty}$	[mm/kN]	0,09	0,08	0,08	0,06	0,06	0,05

**Table C8: Displacements under tension load**

Reinforcing bar (rebar)			$\phi$ 8	$\phi$ 10	$\phi$ 12	$\phi$ 14	$\phi$ 16	$\phi$ 20	$\phi$ 25
<b>Uncracked concrete</b>									
Temperature range I: 40°C / 24°C									
Displacement	$\delta_{N0}$	[mm/(N/mm <sup>2</sup> )]	0,06	0,06	0,06	0,07	0,07	0,07	0,07
Displacement	$\delta_{N\infty}$	[mm/(N/mm <sup>2</sup> )]	0,07	0,07	0,07	0,08	0,08	0,08	0,08
Temperature range II: 80°C / 50°C									
Displacement	$\delta_{N0}$	[mm/(N/mm <sup>2</sup> )]	0,06	0,05	0,05	0,04	0,04	0,04	0,03
Displacement	$\delta_{N\infty}$	[mm/(N/mm <sup>2</sup> )]	0,09	0,08	0,07	0,06	0,06	0,05	0,05

**Injection system Hilti HIT-CT 1**

**Performances**  
Displacements

**Annex C5**

**Table C9: Displacements under shear load**

Reinforcing bar (rebar)			$\phi$ 8	$\phi$ 10	$\phi$ 12	$\phi$ 14	$\phi$ 16	$\phi$ 20	$\phi$ 25
Displacement	$\delta_{v0}$	[mm/kN]	0,09	0,07	0,06	0,05	0,05	0,04	0,03
Displacement	$\delta_{v\infty}$	[mm/kN]	0,14	0,11	0,09	0,08	0,07	0,06	0,05

**Injection system Hilti HIT-CT 1**

**Performances**  
 Displacements

**Annex C5**